

LID

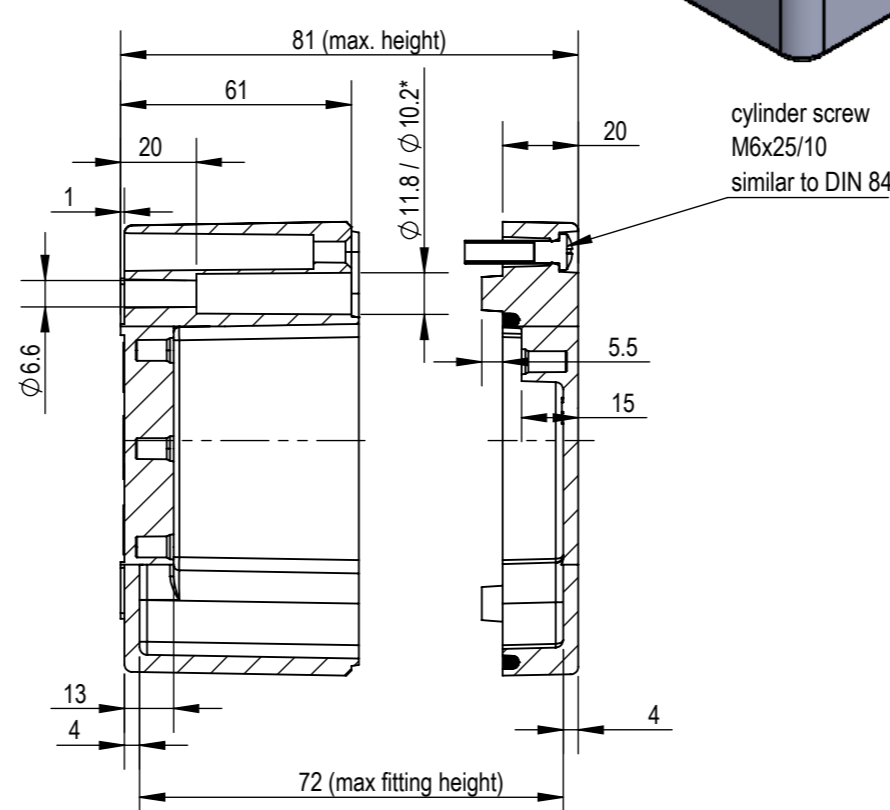
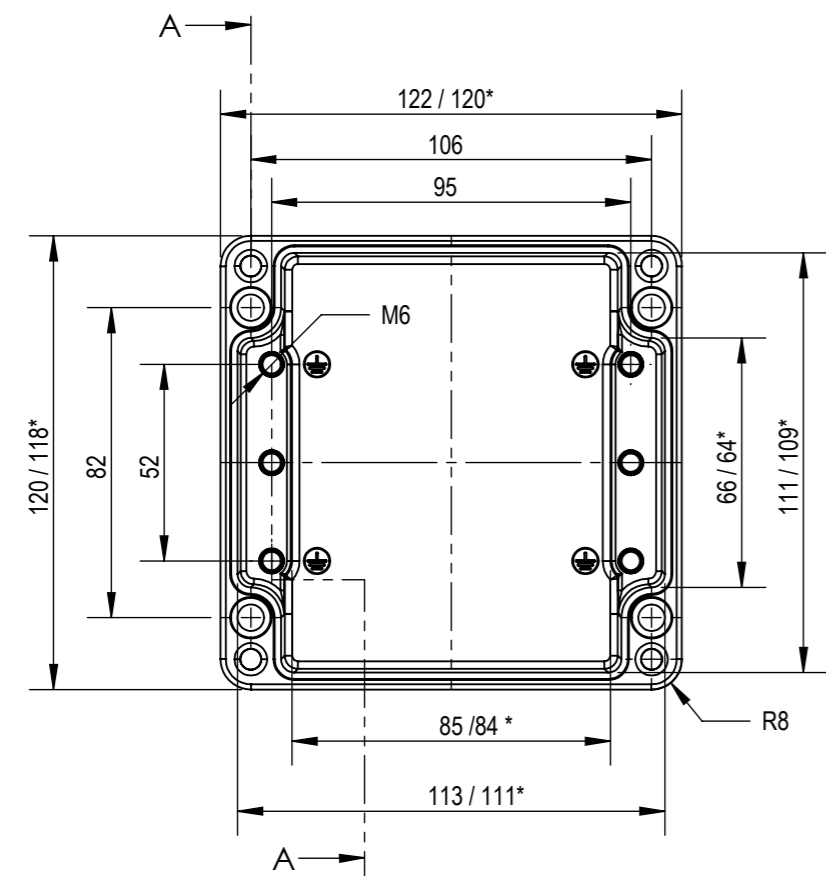
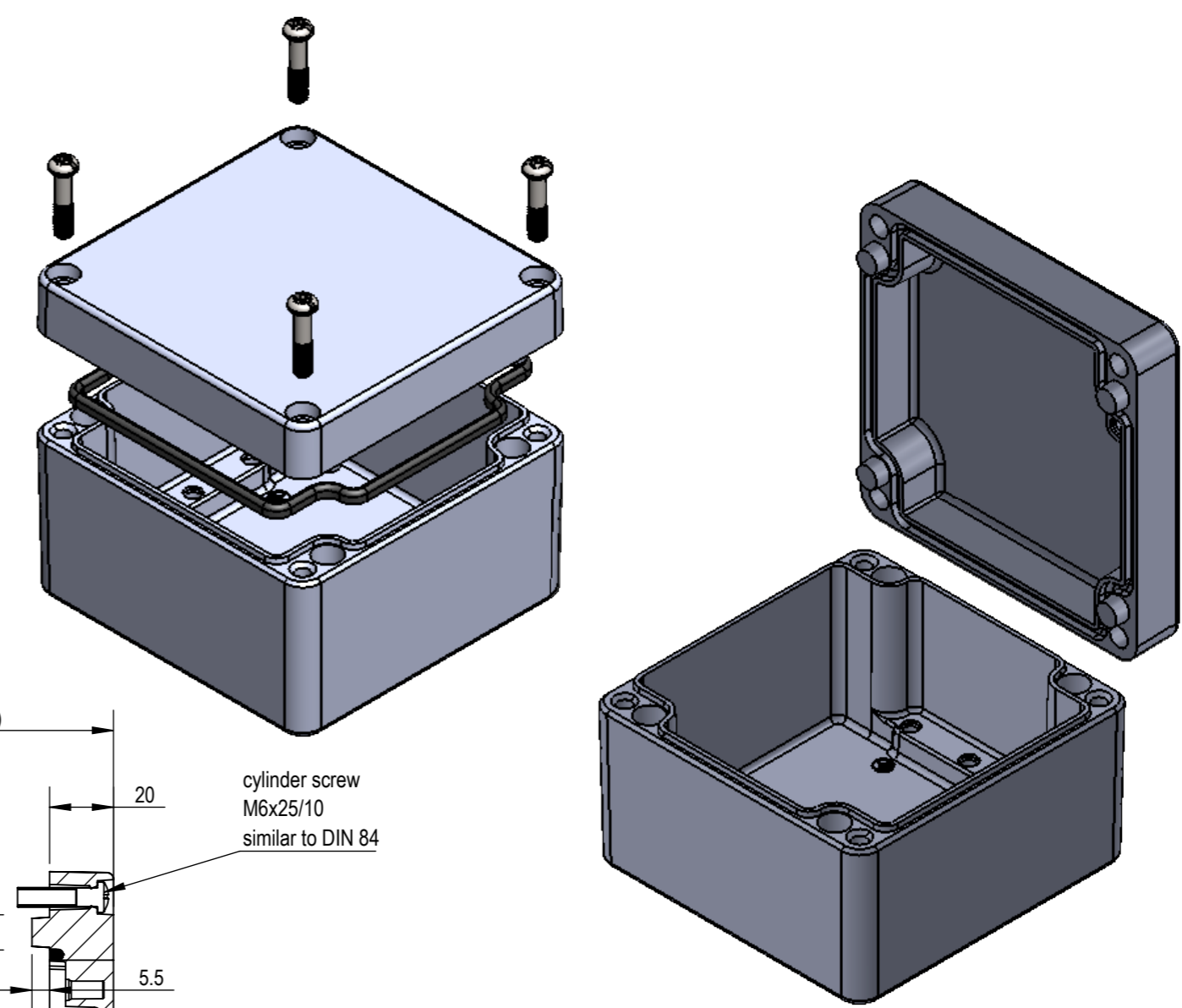
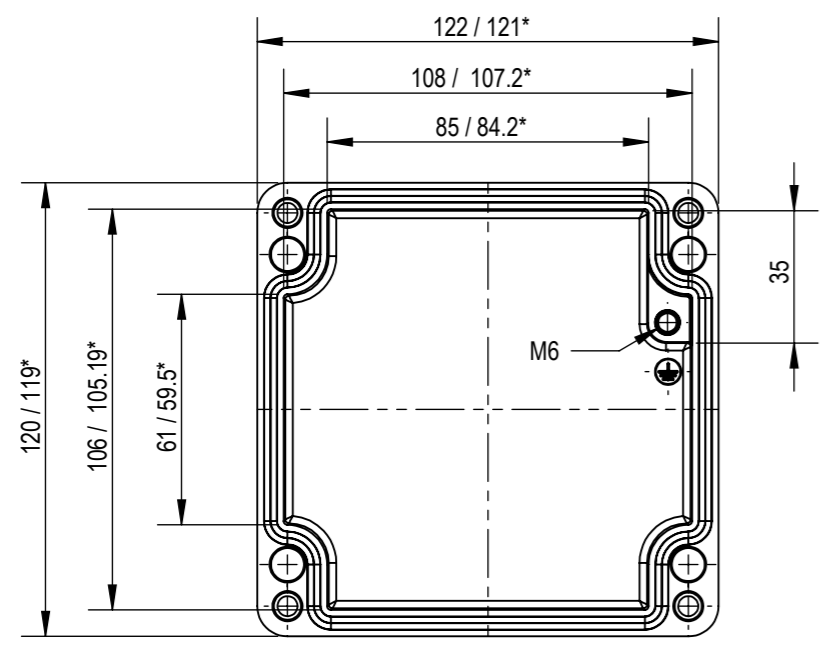

* = Conical form tapering downwards
Free dimensions-tolerance to GTA 13/5DIN 1688

ENCLOSURE/BOX MEETS THE REQUIREMENTS OF
IS/IEC 60529:2001
OR
EN 60529
FOR IP 66 AND IP 68 SEVERITY

BASE

		MANUFACTURER	MODEL	BRAND NAME
TOLERANCE (AS PER) GTA 13/5 DIN 1688			BB 09	
MATERIAL ALUMINIUM ALLOY GdAlSi12(Fe) / DIN1706 / ENAC44300		ALL DIMENSIONS ARE IN : Millimeters (mm)	ENCLOSURE /BOX SIZE L X W X H 120 x122 x 81	
ALL UNSPECIFIED RADII = R 1.5 SALT MIST TEST > 1000 Hrs FINISH NATURAL OR POWDER COATED		SHEET SIZE : A3 SCALE 1:2	DRAWING NO	REVISION NO
PROPRIETY & CONFEDENCIAL : All information in this drawing is the sole property of DEMO CASTERS PVT LTD. Any reproduction in part or as a whole without the written consent of Demo Casters is prohibited.		DATE 23-08-2013 G.A.G CHECKED BY 04-04-2021 RAJ.K.JHA APROVED BY 05-04-2021 V. BIJLANI	DEM-001-09	
		RELEASED		